

STUDENT VERSION MYSTERY CIRCUIT

Brian Winkel
Director SIMIODE
Cornwall NY USA

STATEMENT

We present a two loop circuit (see Figure 2) for analysis. Using different frequency voltages we drive the circuit and asking you and your classmates to report back *gain* (defined below) from the circuit, wherein one can plot the gain versus input voltage frequency data from the entire class to analyze this circuit. Some basic electrical circuit notions are offered from a textbook source we have used [1, pp. 118-119]. Of course, there are other sources, e.g., electrical engineering and circuits texts, physics texts, and web-based material.

Introductory Notions for Circuit Study

Consider a typical one-loop RLC circuit (see Figure 1). R is resistance in ohms, L is inductance in henrys, and C is capacitance in farads, or more usually microfarads. There is an electromotive force, $E(t) = E_0 \sin(\omega t)$, in volts driving the circuit. This voltage produces an alternating current, $I(t)$, in amperes at time t , in the circuit as a measure of the flow of electrons in the particular branch of the circuit.

Kirchhoff's Voltage Law says that in the circuit at all times t the voltage source, $E(t) = E_0 \sin(\omega t)$, equals the sum of the three voltage drops – over R , L , and C , i.e. $E = E_R + E_L + E_C$ (see Figure 1). The voltage drop over each of the devices, resistor R , inductor L , and capacitor C is given by the following formulae, respectively:

$$(R) \quad E_R = RI,$$

$$(L) \quad E_L = LI', \text{ and}$$

$$(C) \quad E_C = \frac{1}{C} \int I(t) dt.$$

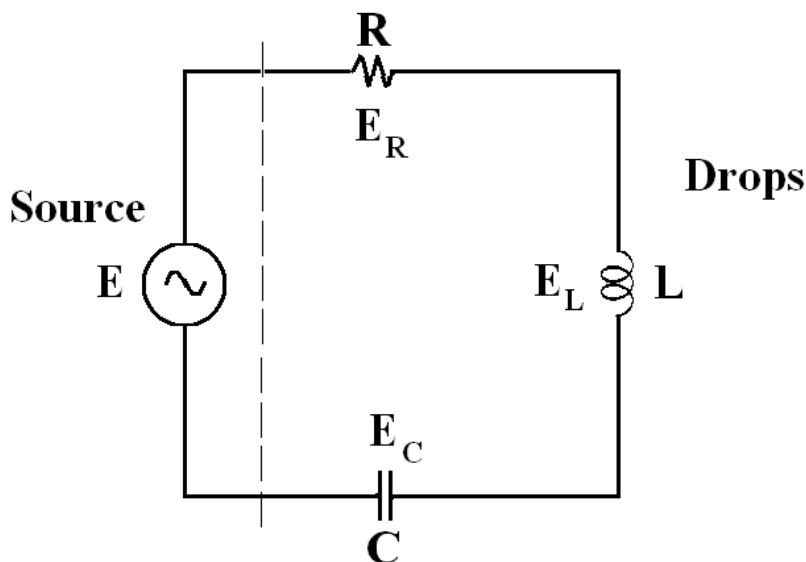

Figure 1. Single loop RLC circuit.

Consider the following differential equation in $I(t)$, the current in the one loop circuit of Figure 1, using Kirchhoff's Voltage Law as an elementary example of Figure 2. Sum the voltages across the resistor, the inductor, and the capacitor and set this sum equal to the voltage from our source or driver, $E(t)$:

$$LI'(t) + RI(t) + \frac{1}{C} \int I(t) dt = E_0 \sin(\omega t) . \quad (1)$$

Convert this into a second order differential equation in $I(t)$ by differentiating both sides with respect to t :

$$LI''(t) + RI'(t) + \frac{1}{C}I(t) = E_0\omega \cos(\omega t) . \quad (2)$$

Note that prior to the voltage source being applied there is nothing happening in the circuit, i.e. there is no voltage or force to move the electrons in the circuit. Hence, the reasonable initial conditions are $I(0) = 0$ and $I'(0) = 0$.

Consider the electrical circuit in Figure 2 and we give each student a unique parameter - the frequency of the driver voltage, i.e. ω . Each student should take a different input frequency, ω , and model the circuit, solve for the gain associated with the specific assigned parameter, and report back this gain value. The data is to be collected in class where it will be plotted to see what can be inferred from such a display. Describe what this circuit really does. The circuit offered is shown in Figure 2.

The values for this circuit are $C_1 = 2.5 \times 10^{-6}$ F (farads), $C_2 = 1.0 \times 10^{-6}$ F, $R_1 = 200 \Omega$ (ohms), and $R_{\text{load}} = 1000 \Omega$. Use $E(t) = \sin(\omega t)$ (volts) with $\omega = 100$ (radians/sec) as a trial run.

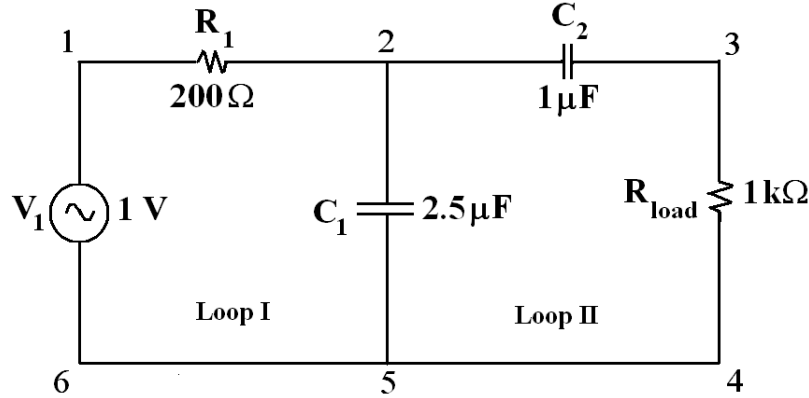

Figure 2. Two loop RLC circuit.

Activity

- 1) Build equations to describe this two loop circuit using *Kirchhoff's Voltage Law* as above and *Kirchhoff's Current Law* which says that the sum of the currents at any node in the circuit must be 0, i.e. what goes into the node has to go out without loss or gain.

We identify variables:

$x(t)$ is the current from Point 1 to Point 2,

$y(t)$ is the current from Point 2 to Point 5, and

$z(t)$ is the current from Point 2 to Point 3 to Point 4 to Point 5.

One way to measure the behavior of this circuit is to compare the amplitude of the “output” voltage $z(t)R_{\text{load}}$ (recall voltage is current times resistance!) with that of the input voltage $E(t)$.

From Kirchhoff's two laws one can find the relationship between the source voltage, $E(t)$, in Loop I and the sum of the voltages across the devices in Loop I,

$$\sin(100t) = x(t)R_1 + \frac{1}{C_1} \int y(t) dt \quad (3)$$

and in Loop II using the resultant voltage across C_1 as a source voltage and adding the voltages across C_2 and R_{load} ,

$$\frac{1}{C_1} \int y(t) dt = \frac{1}{C_2} \int z(t) dt + z(t)R_{\text{load}} . \quad (4)$$

Finally, use Kirchhoff's Current Law at node 2 to relate the three currents, $x(t)$, $y(t)$, and $z(t)$.

Imposing initial conditions that all currents and all change (derivative) in currents are 0, we have in (1), (2), and (3) what we need to solve for each of the three currents, $x(t)$, $y(t)$, and $z(t)$. In particular, we can solve for $z(t)$ and determine the amplitude of $z(t)R_{\text{load}}$, the output voltage, to compare to the amplitude of $E(t) = \sin(100t)$, the input voltage as a ratio. This ratio of the

amplitude of the output voltage to the amplitude of the input or source voltage is called *gain* and we seek the gain for various input voltage frequencies ω (frequency here is in radians/second) with $\omega = 100$ being the trial run frequency. We recall that the input or source voltage frequency is exactly the same as the output voltage and so in studying gain we are merely comparing amplitudes of the same frequency voltages.

Assignment of Input Voltage Frequencies

We now assign a span of frequencies ω , say from $\omega = 100$ to 10,000, for an input voltages $E(t) = \sin(\omega t)$ and ask you and your classmates to compute a gain over the resistance R_{Load} for the specific assigned frequency in our circuit of Figure 2.

- 2) Use your assigned frequency, ω , and determine your corresponding gain, i.e. the ratio of amplitude of the output voltage to the amplitude of the input or source voltage

When the class has returned with their circuit gains for their respective input frequencies we will plot gain vs. input frequency and see what such a plot shows us when we consider input voltage frequencies ω in the range $(0, 10,000]$.

- 3) For further study, consider the same two loop circuit in Figure 2 and determine the sensitivity of the Gain vs. Voltage input frequency to changes in one or more of the parameters C_1 , C_2 , R_1 , or R_{Load} . Namely, if we change one of these parameters how does such change effect the circuit's performance, its gain attributes?

REFERENCES

- [1] Kreyszig, E. 1999. *Advanced Engineering Mathematics, Eighth Edition*. New York: John Wiley and Sons, Inc.